



TYPICAL

YSC-8320

USER MANUAL

XI'AN TYPICAL INDUSTRIES CO.,LTD.

1	Notice	3
	1.1 Work environment	3
	1.2 Notice of installation	3
	1.3 Notice of safety	3
2	Installation and Adjustment	4
	2.1 Dimension of controll box	4
	2.2 Adjustment of speed controller	4
	2.3 Dimension of speed controller bracket (direct-driven)	4
	2.4 Dimension of identifier	4
	2.5 Dimension of servo motor (direct-driven)	4
	2.6 Dimension of servo motor (belt-driven)	5
	2.7 Installation of magnetic synchronizer	5
	2.8 Installation diagram of system	5
3	Power Connection	6
	3.1 Single phase 220V power connection	6
	3.2 Three phase 380V power connection	6
4	Connector Diagram	7
5	Function of Operation Box	8
6	Operation of the Front Panel	10
	6.1 Diagram of the front panel	10
	6.2 Mode parameter setting	10
	6.3 Setting of speed	15
	6.4 Select of Machine type	16
	6.5 Adjust the tacking	17
	6.6 Slow start function	18
	6.7 Counting the products quantity	18
	6.8 Access the special function parameter interface	19
	6.9 Resume the default value of parameters	19
	6.10 Encrypt the parameter interface	19
7	General Parameter Table	20
	7.1 Speed parameter	20
	7.2 Time parameter	20
	7.3 Enable parameter	21
	7.4 Special function parameter (part)	25

8	Measurement of Error and Warning	26
9	Signal Checking	27
9.1	Speed controller	27
9.2	Inspector	27
9.3	Button signal	27
9.4	Hall signal of servo motor	28
9.5	Encoder of servo motor	28
9.6	Solenoid function	28
9.7	Code of identifier	28
9.8	Version of software	28
9.9	Output voltage of speed controller	28
10	Measurement of History Errors	28
11	Prompt of Adding Grease	29
12	Motor Reversing	29
13	Parameter Solidifying	29
Appendix: 7-segment Display Characters Compare Table		30

1. Notice

YSC-8320 is used in system of industry sewing machine. For perfect operation and safety, installation and operation must be supervised by professional.

1.1 Work environment

- ▲ Please use 220V AC in $\pm 10\%$ ranges.
- ▲ To avoid the false operate, please keep the product away from the high electromagnetic interference.
- ▲ Please operate in the area which temperature is $5^{\circ}\text{C}\sim 45^{\circ}\text{C}$.
- ▲ Please operate in the area which humidity is 80% or less.
- ▲ Please keep the product away from the flammability and exploder.

1.2 Notice of installation

- ▲ The control box should be installed correctly follow the instruction in this manual.
- ▲ Turn off the power and unplug the cord before installation.
- ▲ The wire must not set to be near the wheel and other movable parts.
- ▲ To avoid the static interference and current leakage, all grounding must be done.

1.3 Notice of safety

- ▲ Turn off the power before maintenance and repairs or raising the machine arms, or changing needle, or threading needle.
- ▲ Please don't open the box except the professional.
- ▲ When turn on the machine in the first time, use low speed to operate and check the correct rotation direction.
- ▲ During machine operation, don't touch any moving parts.
- ▲ All moving parts must use the protective device to avoid the body contact and objects insertion.
- ▲ When there is water or other liquid, or caustic material on box or motor, you must stop operation and turn off the power.
- ▲ All connector shouldn't be plug and unplug when power on.
- ▲ The connector should be plug and unplug in the correct method.

2. Installation and Adjustment

2.1 Dimension of control box

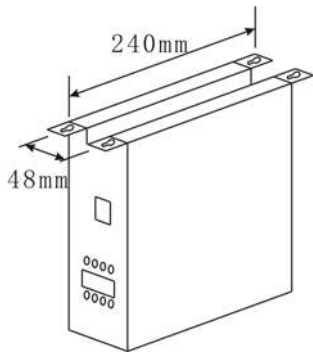

2.2 Adjustment of speed controller

- A: Forward spring
- B: Groove
- C: Bolt group
- D: Back spring
- E: Pothook hole for pedal

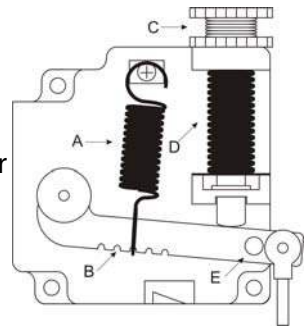

2.3 Dimension of speed controller bracket (direct-driven)

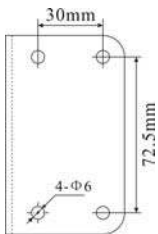

2.4 Dimension of identifier

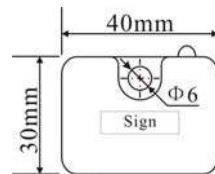
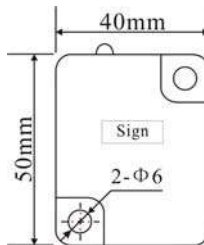

2.5 Dimension of servo motor (direct-driven)

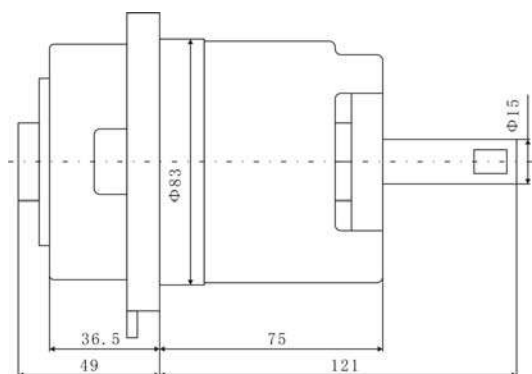
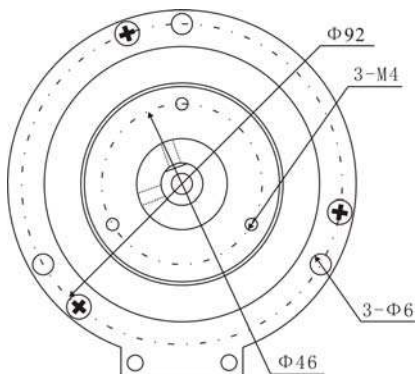

2.6 Dimension of servo motor (belt-driven)

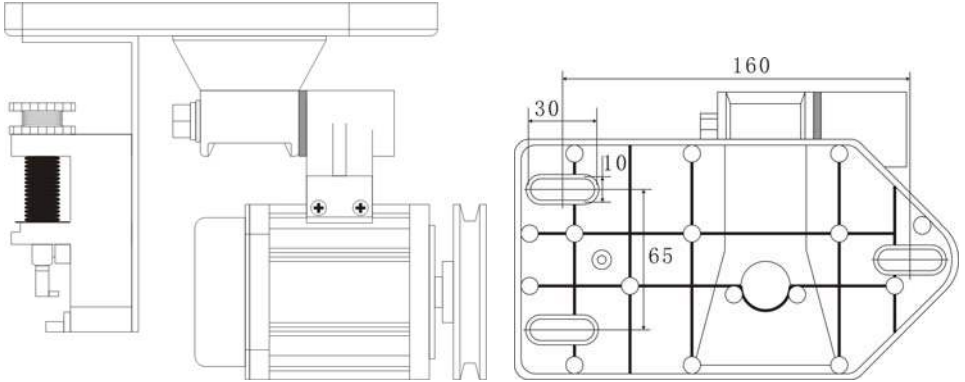

2.7 Installation of magnetic synchronizer

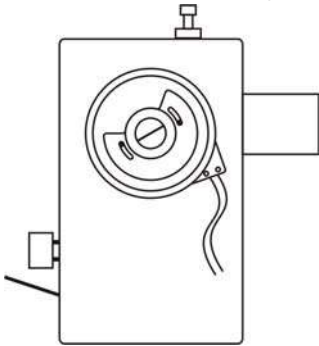

When install the handwheel, the first hole must be vertical to the plane of the main axis.

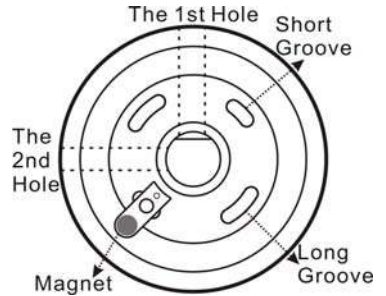

2.8 Installation diagram of system

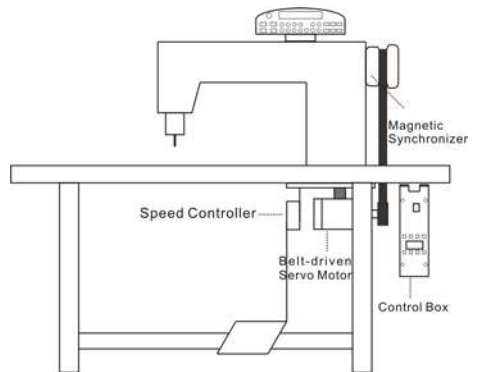
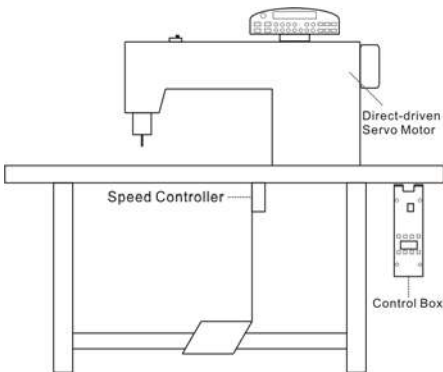

3. Power Connection

3.1 Single phase 220V power connection

Ground wire (green/yellow) must be grounding.

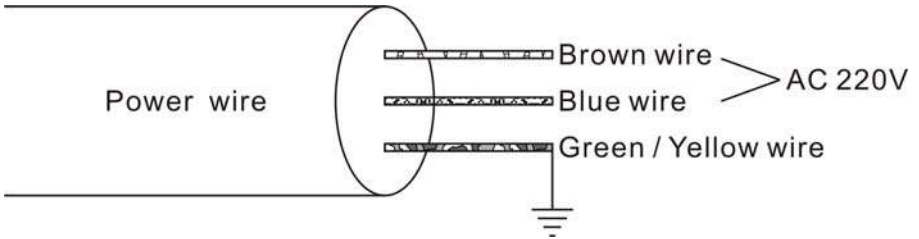

3.2 Three phase 380V power connection

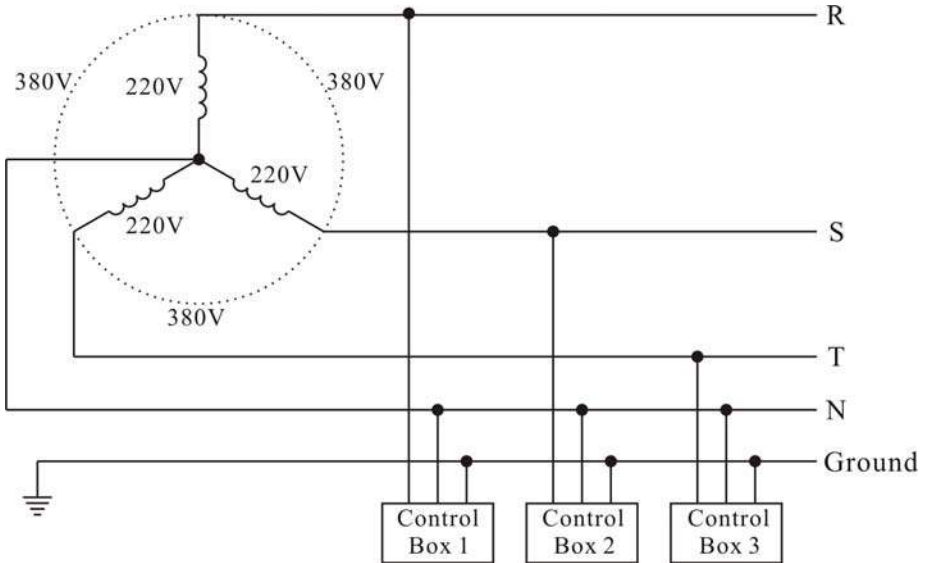

4. Connector Diagram

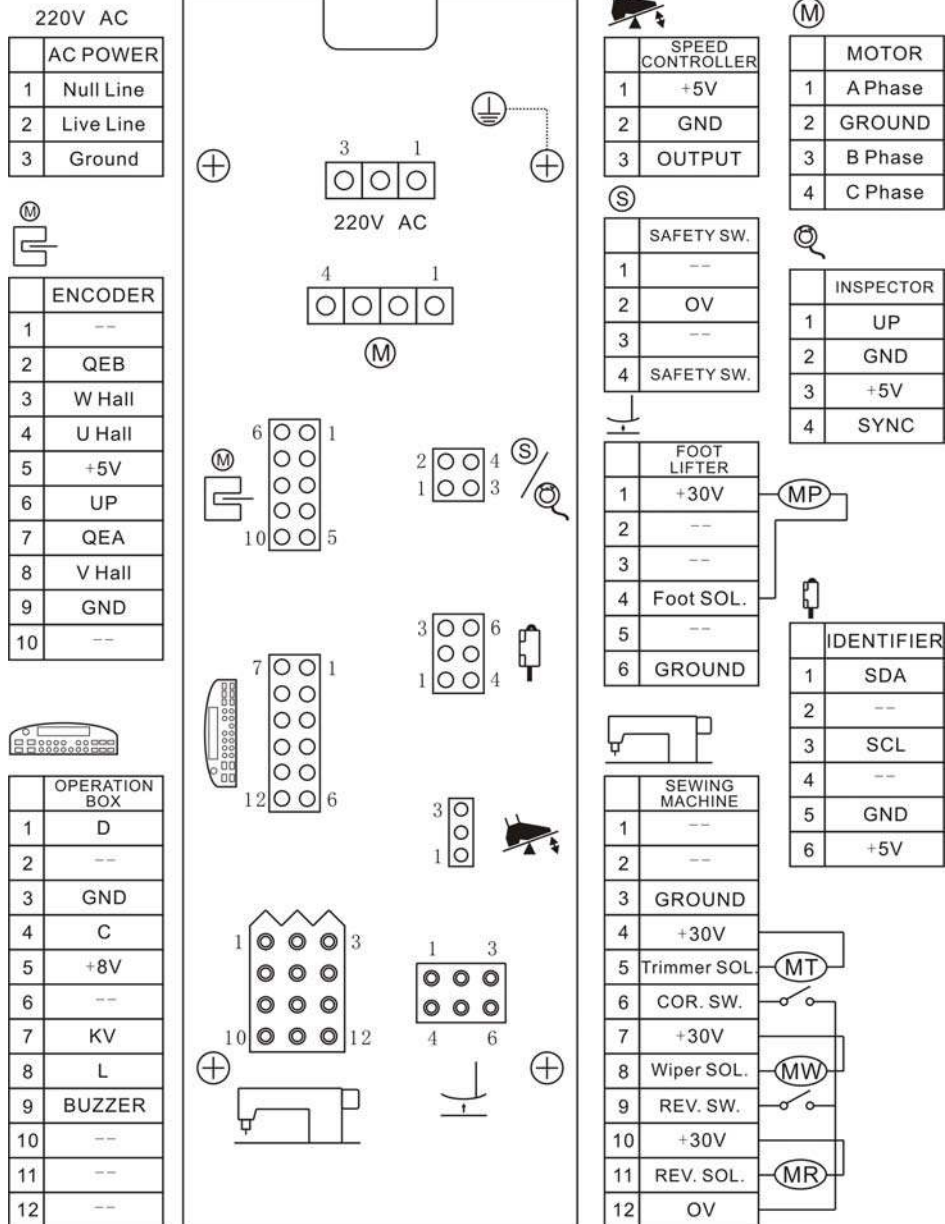







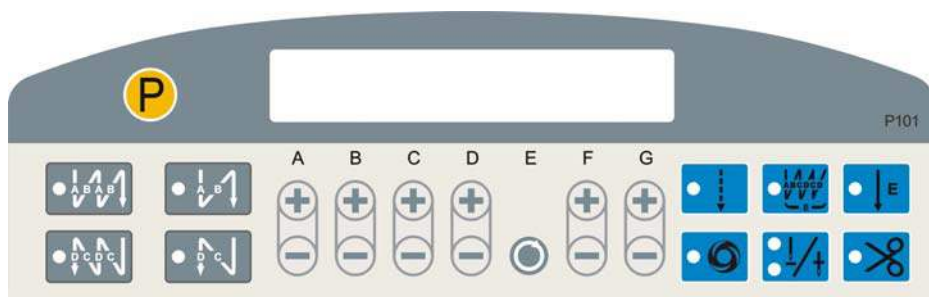





Attention: for direct-driven is safety SW., and for belt-driven is inspector.

5. Function of Operation Box

P101 Operation Box Diagram



Function	Key	Operation
Start Tacking Selection		Double start tacking, A is the stitches of forth sewing; B is the stitches of back sewing. They are both in range 1~15.
		Single start tacking, A is the stitches of forth sewing; B is the stitches of back sewing. They are both in range 1~15.
End Tacking Selection		Double end tacking, C is the stitches of back sewing; D is the stitches of forth sewing. They are both in range 1~15.
		Single end tacking, C is the stitches of back sewing; D is the stitches of forth sewing. They are both in range 1~15.
Free Sewing		<p>▲ As the pedal is stepped forward, the start tacking(if selected) will be done automatically, then machine will start normal sewing. Once the pedal returned to balance, machine will stop immediately.</p> <p>▲ As the pedal stepped backward, the end tacking, trimming and wiping(if selected) will be done automatically.</p>

<p>Bar Tacking Sewing</p>		<p>▲ Once the pedal is stepped forward, all the seams of bar tacking, A, B, C, D sections will be completed with E times, and the trimming will be done automatically.</p> <p>▲ The pedal must be returned to balance for next sewing.</p>
<p>Constant-Stitch Sewing</p>		<p>▲ Once the pedal is stepped forward, F, G stitches will be completed with E times.</p> <p>▲ Constant-Stitch Sewing will perform the number of segments and times as setting, when the stitches are zero, machine will stop immediately.</p> <p>▲ If the button  is set “ON”, the Constant-Stitch Sewing will perform automatically as setting. If it is set “OFF”, machine will stop immediately once the pedal returned to balance. As the pedal is stepped forward again, the rest stitches of current segment will be completed.</p>
<p>Switch Selection</p>		<p>Set the number of segment in Bar Tack or Constant-Stitch Sewing, or parameter type.</p>
<p>Constant-Stitch Sewing Automation Selection</p>		<p>It is available only for constant-stitch sewing. When it is set “ON”,</p> <ol style="list-style-type: none"> Once step forward, automatically performed the stitches of setting. Repeat the action to finish rest the sections until it finished.
<p>Needle Up / Needle Down</p>		<p>Select the stop position of needle.</p>
<p>Trimming Enable</p>		<p>Enable or disable the trimming.</p>
<p>Parameter Function</p>		<p>Enter or exit parameter function interface.</p>

6. Operation of the Front Panel

6.1 Diagram of the front panel

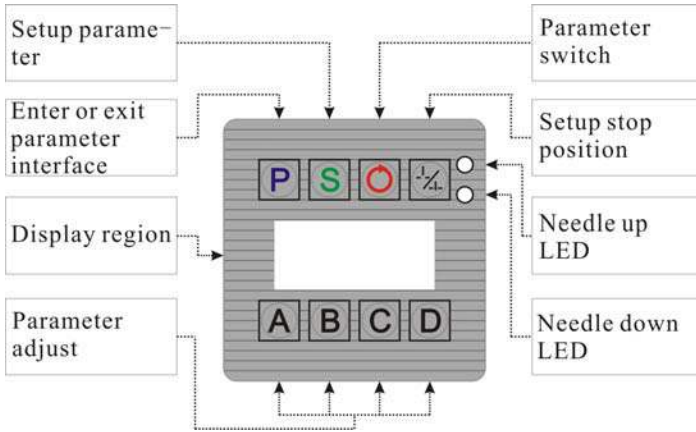

6.2 Mode parameter setting

6.2.1 Mode 1 (Free sewing)

a. How to access the free sewing

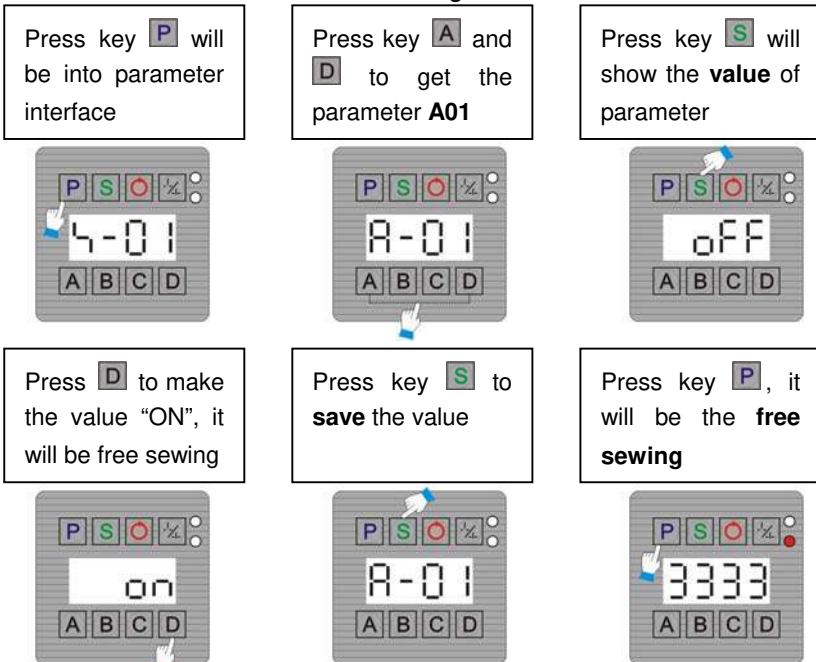

b. How to set the times of start tacking

Get the parameter
A07, press key **S**
it will show the value



Press **D** to make
the value "ON", it
will be **single start**



Press **S** to save
the value, result as
below



Get the parameter
A09, press key **S**
it will show the value



Press **D** to make
the value "ON", it
will be **double**



Press **S** to save
the value, result as
below

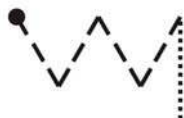

If **A07** and **A09**
are both "OFF", it
will be **no start**

c. How to set the times of end tacking

Get the parameter
A06, press key **S**
it will show the value



Press **D** to make
the value "ON", it
will be **single end**



Press **S** to save
the value, result as
below



Get the parameter **A08**, press key **S** it will show the value



Press **D** to make the value "ON", it will be **double**



Press **S** to save the value, result as below



If **A07** and **A09** are both "OFF", it will be **no end**

d. how to set the stitch of start/end tacking

Press **A** and **B** to set the stitch

The forth and back **stitch of start** as below



Press **C** and **D** to set the stitch

The back and forth **stitch of end** as below



6.2.1 Mode 2 (Bar tacking sewing)

a. How to access the bar tacking sewing

Get the parameter **A02**, press key **S** will show the value



Press **D** to make the value "ON", and **S** to save



Press key **P**, it will be the **bar tacking sewing**

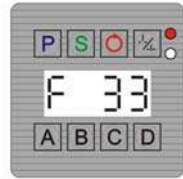

b. How to set the stitch of the first round

Press **O** to show the stitch of first round



Press **C** and **D** to set the forth and back **stitch of first round**



The forth and back **stitch of first round** as below

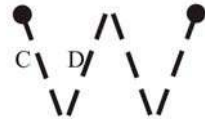

c. How to set the stitch for other round

Press **O** to show the stitch of other round



Press **C** and **D** to set the forth and back **stitch of else round**



The forth and back **stitch of else round** as below



d. How to set the times of bar tacking sewing

Press **○** to show the times



Press **D** to set the times



Result as below



6.2.1 Mode 3 (Constant-stitch sewing)

a. How to access the constant-stitch sewing

Get the parameter **A03**, press key **S** will show the value



Press **D** to make the value "ON", and **S** to save



Press key **P**, it will be the C-S sewing



b. How to set the segments and stitch

Press **○** to show the segment and stitch



A to set segment (1~15), **C D** to set the stitch (0~99)



c. How to set the stitch of start tacking

Press **S** to show the stitch of start



Press **C** and **D** to set the stitch of start



The forth and back stitch of start as below

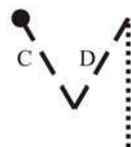

d. How to set the stitch of end tacking

press **S** to show the stitch of end



Press **C** and **D** to set the stitch of end



The forth and back stitch of end as below



e. The setting of start/end tacking times is similar to the free sewing, the parameter are **A10**, **A11**, **A12** and **A13**.

6.3 Setting of speed

6.3.1 How to set the max speed

Get the parameter **S01**, press **S** to show the value



Press **A~D** to set the max speed, press **S** to save



6.3.2 The setting of other speed is similar above.

6.4 Select of Machine type

The machine type code (**O03**) is associated with identifier automatically, the parameter relative would refresh according to machine type. If any wrong with the identifier, it can be disabled and set by manual, as below:

- ▲ Press **B** during power on, "ID D" would be displayed then the identifier is disabled;
- ▲ Set **O03** to according with machine type;
- ▲ Set **O30** to be "ON" will re-enable the identifier function.

The default value of some parameters are different from machine type, as below:

Default Code	S01	S03	S04	S05	S06	T01	T02	A16	O31	O32	O33
01	4000	1800	1800	1800	3000	45	42	OFF	ON	1	1440
02	3000	1800	1800	1800	2000	53	48	OFF	ON	1	1440
03	4000	1800	1800	1800	3000	45	42	OFF	ON	1	1440
04	3000	1800	1800	1800	2000	53	48	OFF	ON	1	1440
05	3500	1500	1500	1500	3000	70	55	OFF	ON	1	1440
06	2500	1500	1500	1500	2000	70	55	OFF	ON	1	1440
07	4000	1800	1800	1800	3000	55	40	ON	OFF	0	1440
08	3000	1800	1800	1800	2000	59	45	ON	OFF	0	1440
09	2000	1000	1000	1000	1500	55	45	OFF	OFF	0	1618
10	4000	1800	1800	1800	3000	55	40	OFF	OFF	0	1440
11	3000	1800	1800	1800	2000	59	45	OFF	OFF	0	1440
12	3500	1800	1800	1800	2000	45	31	OFF	OFF	0	1440
13	2500	1800	1800	1800	2000	55	45	OFF	OFF	0	1440
14	3500	1800	1800	1800	2000	57	46	OFF	OFF	0	1440

6.5 Adjust the tacking

6.5.1 Adjusting of RVE. SOL. action time

For start/end tacking or bar tacking, if unbalanced situation is appeared during natural direction to reverse direction, please correct it as below:



Find parameter **T01**
(RVE. SOL. action
time), decrease it.

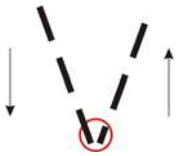

Find parameter **T01**
(RVE. SOL. action
time), increase it.

6.5.2 Adjusting of RVE. SOL. release time

For start/end tacking or bar tacking, if unbalanced situation is appeared during reverse direction to natural direction, please correct it as below:

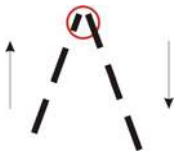

Find parameter **T02**
(RVE. SOL. release
time), decrease it.

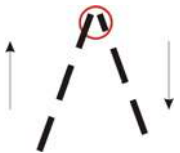

Find parameter **T02**
(RVE. SOL. release
time), increase it.

6.6 Slow start function

If the Stitches of slow sewing at start (**O01**) is non-zero, the speed of next start would be slow sewing speed (**S08**) during the stitches of **O01**, and then associated with speed controller, as below:

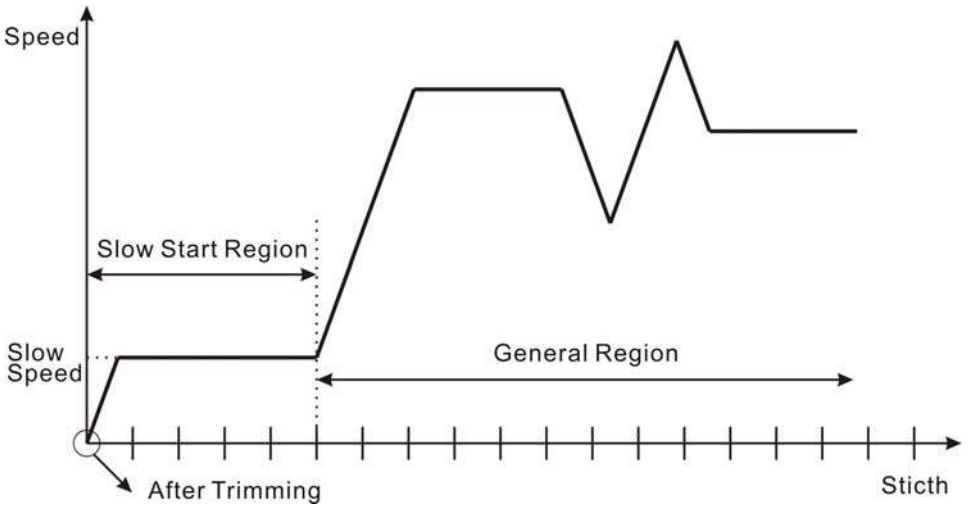

6.7 Counting the products quantity

The quantity add 1 after trimming automatically, counting range is 0~9999, as below:

Find parameter A30	Set to "ON"	Display the products quantity
Add 1 after trimming	Correct by manual	Press P to exit

6.8 Access the special function parameter interface

Press **P** during power on



It will show "O EN"



Then could select the O parameter

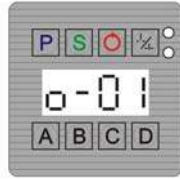

6.9 Resume the default value of parameters

Find parameter **O17**



Set to "ON"



Press **S** to save



Turn on power again



Display "INIT" sparkingly



Then the resumption accomplish



6.10 Encrypt the parameter interface

Find parameter **O21**



Set to "ON" and save



Then the password needed next time



Press **P** after set



Display "OK" if right,
then enter parameters
interface



Display "NO" if wrong,
then can't enter
parameters interface

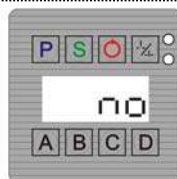

7. General Parameter Table

7.1 Speed parameter

SN	Name	Range	Default	Description
S01	Max speed	500~5000 (s/m)	See Page 16	Maximum speed.
S02	Min speed	150~500 (s/m)	150	Minimum speed.
S03	Speed of start tacking	500~2000 (s/m)	See Page 16	Speed of start tacking.
S04	Speed of end tacking	500~2000 (s/m)	See Page 16	Speed of end tacking.
S05	Speed of bar tacking sewing	500~2000 (s/m)	See Page 16	Speed of bar tacking sewing.
S06	Speed of C-S sewing	500~4000 (s/m)	See Page 16	Speed of constant-stitch sewing, Valid only when A14 is "ON".
S07	Trimming speed	150~300 (s/m)	200	Speed adjustment for trimmer.
S08	Slow sewing speed	200~500 (s/m)	400	Slow sewing speed when start.

7.2 Time parameter

SN	Name	Range	Default	Description
T01	RVS action time	1~200 (ms)	See Page 16	Action time of the REV SOL.

T02	RVS release time	1~200 (ms)	See Page 16	Release time of the REV SOL.
T03	Action time of trimming	1~200 (ms)	110	Timing before the trimmer solenoid is act.
T04	Delay time of wiping	1~200 (ms)	20	Timing before the wiper solenoid is act.
T05	Action time of wiping	1~200 (ms)	30	Timing of the wiper solenoid is act.
T06	Delay time of foot lifter	1~500 (ms)	10	Timing before the foot lifter solenoid is act.
T07	Release time of foot lifter	1~500 (ms)	50	Timing before the foot lifter solenoid is released.
T08	Time of foot lifter whole output	1~999 (ms)	500	Timing of the foot lifter solenoid is act with whole output.
T09	Time of RVS whole output	1~999 (ms)	150	Timing of the reverse solenoid is act with whole output.
T10	Sensitivity time of Stitch correction	1~200 (ms)	20	The action will be greater sensitive when the value is smaller.
T11	Sensitivity time of keyboard	1~300 (ms)	150	The keyboard will be greater sensitive when the value is smaller.
T12	Time of remove shake	1~500 (ms)	100	The speed controller will be greater sensitive when the value is smaller.

7.3 Enable parameter

SN	Name	Range	Default	Description
A01	Free sewing	ON~ OFF	ON	When set to "ON", the free sewing is enable.
A02	Bar tacking sewing	ON~ OFF	OFF	When set to "ON", the bar tack sewing is enable.
A03	C-S sewing	ON~ OFF	OFF	When set to "ON", the constant-stitch sewing is enable.
A04	Up position	ON~ OFF	OFF	When set to "ON", the stop position will be up.
A05	Down position	ON~	OFF	When set to "ON", the stop position will

		OFF		be down.
A06	End tacking 1 times of free sewing	ON~ OFF	ON	When set to "ON", the end tacking of free sewing is 1 times.
A07	Start tacking 1 times of free sewing	ON~ OFF	ON	When set to "ON", the start tacking of free sewing is 1 times.
A08	End tacking 2 times of free sewing	ON~ OFF	OFF	When set to "ON", the end tacking of free sewing is 2 times.
A09	Start tacking 2 times of free sewing	ON~ OFF	OFF	When set to "ON", the start tacking of free sewing is 2 times.
A10	End tacking 1 times of C-S sewing	ON~ OFF	ON	When set to "ON", the end tacking of constant-stitch sewing is 1 times.
A11	Start tacking 1 times of C-S sewing	ON~ OFF	ON	When set to "ON", the start tacking of constant-stitch sewing is 1 times.
A12	End tacking 2 times of C-S sewing	ON~ OFF	OFF	When set to "ON", the end tacking of constant-stitch sewing is 2 times.
A13	Start tacking 2 times of C-S sewing	ON~ OFF	OFF	When set to "ON", the start tacking of constant-stitch sewing is 2 times.
A14	Automatically sewing	ON~ OFF	ON	Valid only in constant-stitch sewing, when set to "ON", enable the automatic sewing.
A15	Stitch correction with single button	ON~ OFF	OFF	For free sewing, if there is single switch on machine arms, when set to "OFF" the switch is reverse switch always. When set to "ON", the switch is reverse switch at sewing and is stitch correction switch at stop.

A16	Stitch correction with double button	ON~ OFF	See Page 16	When set to "ON", enable the reverse and stitch correction switch both are valid. When set to "OFF", disable the double key be valid at the same time, and in this mode, the function of the single switch is determined by A15 .
A17	Trimming	ON~ OFF	ON	When it is "ON", enable the trimming.
A18	Wiping	ON~ OFF	ON	When it is "ON", enable the wiping. When A17 is "OFF", A18 is invalid.
A19	Foot lift	ON~ OFF	ON	When it is "ON", enable foot lift. Whether the foot SOL to be connected is detected during power on automatically.
A20	Foot lift after stop	ON~ OFF	OFF	When A19 is "ON", if A20 is set to "ON", the foot lifter will lift automatically after stop in free sewing and constant-stitch sewing.
A21	Foot lift after trimming	ON~ OFF	OFF	When A19 is "ON", if A20 is set to "ON", the foot lifter will lift automatically after trimming.
A22	The first segment keep on with the start tacking of C-S sewing	ON~ OFF	ON	It is valid only for constant-stitch sewing. If enable automatic sewing mode and set the start tacking, the next segment of constant-stitch sewing will do automatically after the start tacking is finished when A22 is "ON". When it is "OFF" or disable the automatic sewing mode, machine will stop automatically after the start tacking is finished.

A23	The end tacking keep on with the last segment of C-S sewing	ON~ OFF	ON	It is valid only for constant-stitch sewing. If enable automatic sewing mode, the end tacking and trimming will do automatically after the last segment of constant-stitch sewing is finished when it is "ON". When it is "OFF" or disable the automatic sewing mode, machine will stop automatically after the last segment of constant-stitch sewing is finished. The end tacking and trimming will do until step forward the pedal again.
A24	Stitch correction for whole stitch of C-S sewing	ON~ OFF	OFF	It is valid only when A26 is "ON". When it is "ON", stitch correction is only to be whole stitch in constant-stitch sewing. When it is "OFF", it can be half.
A25	Stitch correction for whole stitch of free sewing	ON~ OFF	OFF	When it is "ON", stitch correction is only to be whole stitch in free sewing. When it is "OFF", it can be half.
A26	Stitch correction of C-S sewing	ON~ OFF	OFF	When it is "ON", stitch correction function of constant-stitch sewing is enabled.
A27	Move to up position after power on	ON~ OFF	OFF	When it is "ON", the machine will move to up position and stop automatically as power on.
A28	Foot lifer acting in foot lift position	ON~ OFF	ON	When the pedal is half back toe down, if it is "ON", the position is foot lift. If it is "OFF", the position is balance.
A29	Trimmer acting in foot lift position	ON~ OFF	OFF	When it is "ON", the trimming will at the foot lifter position.
A30	Counting the products quantity	ON~ OFF	OFF	See Page 18.

7.4 Special function parameter (part)

Note: Don't change these parameters without permission.



SN	Name	Range	Default	Descriptions
001	Stitches of slow sewing at start	0~10	0	The stitches of slow sewing at start when trimming is finished. The speed of slow sewing is set in S08 .
003	Machine type	1~30	See Page 16	According to the machine type.
005	Duty of foot lifter output	10~99 (%)	50	The duty cycle of PWM for signal of foot lifter solenoid. The power will be greater if this value is bigger, at the same time, the heat is more.
006	Foot lifter release timed	ON~OFF	ON	When it is "ON", the foot lifter solenoid will be released automatically after the time desired.
017	Initialization of parameters	ON~OFF	OFF	See Page 19.
021	Password required to change parameters	ON~OFF	OFF	See Page 19.
023	Run time of lasting mode	1~60 (s)	5	The run time of lasting mode.
024	Stop time of lasting mode	1~60 (s)	5	The stop time of lasting mode.
025	Total time of lasting mode	1~255 (h)	1	The total time of lasting mode. It will be finished automatically when reached the time.
026	Lasting mode enable	ON~OFF	OFF	When it is "ON", the lasting mode will be active.
029	Safety SW. mode	0~1	1	0: Normal close; 1: Normal open.
030	Identifier enable	ON~OFF	ON	See Page 16.

O31	Safety SW. enable	ON~ OFF	See Page 16	When it is "ON", the Safety SW is enable.
O32	Motor drive mode	0~1	See Page 16	0: Belt driven mode; 1: Direct driven mode.
O33	Scale	0~2000	See Page 16	The scale between motor from machine.
O52	Motor reverse enable	ON~ OFF	OFF	See Page 29.

8. Measurement of Error and Warning

Error code	Causation	Measurement
E01	Voltage is too high	Check the AC power.
E02	Voltage is too low	Check the AC power.
E03	Load is too heavy	Check the load.
E04	Pedal error	Check speed controller, see page 27.
E05	Position check error	Check inspector, see page 27.
E06	Encoder of motor error	Check encoder, see page 28.
E07	Machine type error	Check identifier, see page 28 and 16.
E08	Trimmer SOL error	Check SOL whether direct short.
E09	REV SOL error	Check SOL whether direct short.
E10	Wiper SOL error	Check SOL whether direct short.
E11	Foot lifter SOL error	Check SOL whether direct short.
PEdL	Pedal warning	Release the pedal to balance position.
CrE	Safety SW warning	Check Safety SW, or set O29 to match machine type.
]	Inspector disconnected warning	Motor still can run, but all output signals will be invalid.

9. Signal Checking

Press  during power on, it will display “TEST” and then enter the mode of Measurement of Input Signal. Press  to change the checking item, press  to show currently SN.

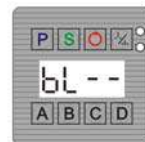

9.1 Speed controller

A, B denote the position of pedal, C, D denote the pull.

Display of the different pedal position as below:

Display code	Meanings	Descriptions
FS02~FS99	High speed	The second segment forward, pull is 02~99.
LS01	Low speed	The first segment forward, pull is 01.
BL--	Balance	Default.
FP--	Foot lifter	The first segment backward.
TM--	Trimming	The second segment of backward.
ERRO	Fault	Speed controller fault or disconnected.

9.2 Inspector

A, B denote the up position, C, D denote the down position.

Turn the hand wheel by hand equably, display of different position as below:



Display code	Meanings	Descriptions
UP--	Needle up position	In up position.
--DW	Needle down position	In down position.
----	Other position	Neither in up or down position.
ERRO	Fault	Both in up and down position.

9.3 Switch signal

A denote SYNC of inspector, B denote REV SW, C denote COR SW, D denote Safety SW. “0” to open, “1” to close.



9.4 Hall signal of servo motor

Turn the hand wheel by hand equably, display the hall signal of motor, range is 0~7. If the fault state appeared, then display “ERRO”.



9.5 Encoder of servo motor

Turn the hand wheel by hand equably, display the encode count of motor, up to **O33** then reset, the error is ± 5 normally.



9.6 Solenoid function

Through **A~D** to test the SOL, as below:

- A** -- Trimmer SOL **B** -- REV SOL
- C** -- Wiper SOL **D** -- Foot Lifter SOL

“N” denote no action, “A” denote acting.



9.7 Code of identifier

Display the code of identifier, see page 16. Display “ERRO” while fault.



9.8 Version of software

For example, the version is v 1.00.



9.9 Output voltage of speed controller

Display the output voltage of speed controller, unit is $\times 0.01V$.



10. Measurement of History Errors

The system can save the error code automatically when error occurred.

Checking the history error by operation as below:

- ▲ Press **D** during power on, then display “ER D”;
- ▲ Press **A** to check the 10 error code of recent;
- ▲ Display “NO” if there is no error;
- ▲ Else display the error code, see page 26.

11. Prompt of Adding Grease

The whole operating stitches would be saved in memory hardware. If this quantity of direct-driven machine is more than 2 hundred million, sparking “OIL” would be displayed to tell user adding grease, during the time press  to confirm, then become to wait the next 2 hundred million stitches.

If press  during power on, the times of user confirm and whole operating stitches would be displayed as below:

For example: user confirm 1 time, and the machine has been ran 1.5 hundred million stitches.

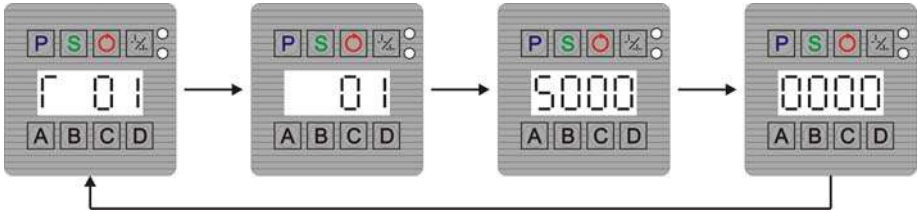

12. Motor Reversing

If machine head locked, the function of motor reversing would be useful. Operating as below:

- ▲ Press  during power on, then display “RV E”;
- ▲ Through pedal to run motor reversing;
- ▲ If the problem solved, set parameter **O52** “OFF” to resume normal status.

13. Parameter Solidifying

If user want to change some parameter’s default value, operating as below:











Select parameter (such as **T01**), press  to solidify.

Display “S OK” after accomplished, then the default of **T01** is changed to user’s setting.





























Appendix: 7-segment Display Characters Compare Table

Arabic Number

Actual	0	1	2	3	4	5	6	7	8	9
Display										

English Alphabet

Actual	A	B	C	D	E	F	G	H	I	J
Display										
Actual	K	L	M	N	O	P	Q	R	S	T
Display										
Actual	U	V	W	X	Y	Z				
Display										

Add: No.1 Taibai South Road,
Xi'an, P.R.China-710068

Tel: +86-29-88279162 88279163

Fax: 029-88279161 83911111

E-mail: typical@chinatypical.com

[Http://www.chinatypical.com](http://www.chinatypical.com)

V1